

A GUIDE TO THE FA KIT AND ADVERTISING REGULATIONS

SEASON 2020-2021



FOR ALL

CONTENTS

INTRODUCTION	4
DEFINITIONS & INTERPRETATION INTRODUCTION	4
GENERAL	4
PERMITTED ADVERTISING (NOT RELATED TO SPONSORS)	5
CLUB EMBLEM (DIAGRAMS)	10
CLOTHING MANUFACTURER (DIAGRAMS)	12
SPONSOR DESIGNATIONS	13
SPONSOR DESIGNATIONS (DIAGRAMS)	15
MEASUREMENT PROCEDURES	17
MATCH OFFICIALS	19

KIT AND ADVERTISING REGULATIONS

Introduction

These Regulations are made pursuant to FA Rule J2 and The Association's Regulation's for the Registration and Control of Referees. Clubs are also referred to the Laws of the Game.

All references to a club or clubs in these Regulations include any team, whether or not part of a club.

Clubs participating in International competitions must also comply with all relevant regulations of FIFA, UEFA and other Confederations.

It is recommended that clubs and football boot and clothing manufacturers seeking clarification of any of the regulations do so by referring to the specific competition rules and The Association.

We would encourage clubs and football boot and clothing manufacturers to seek feedback at the earliest possible time, in relation to designs and advertising from The Association and their specific competition. Clubs and manufacturers are reminded to obtain the necessary permissions before manufacture.

Definitions and Interpretation

"Advertising" means any designation, message, logo, trademark, name or emblem of any nature.

"Clothing" means the Match clothing of a Player, Club Official or Match Official and shall include without limitation shirts, shorts, socks, undershorts, t-shirts (or any other item of clothing worn under the shirt), sweat-bands, headbands, hairbands, caps, captain's armband, tracksuits, "walk on" jackets (i.e. that worn by Players for the pre-match player line up), gloves, waterproofs, sweat tops, sock tie-ups. Also, any outer garments worn by substitutes and Club Officials in the Technical Area at any time. Save where stated to the contrary, Football Boots are not considered as Clothing.

"Clothing manufacturer" means any undertaking that carries out the business of the manufacture or licensing of football clothing and has been appointed by the Club concerned to supply the clothing.

"Club Officials" in these Regulations includes any Club Official as defined in the Rules who has team duties such as managers, coaches, physiotherapists, and doctors and includes any person who takes up a position in the Technical Area at any time during a Match.

"Football Boots" means any footwear worn during the period of a Match by a Player or Match Official.

"Other Equipment" means medical bags, kit bags, blankets, towels, bottles and any medical equipment worn by a Player (including head protection, face masks, casts, kneepads or knee braces, elbow pads) that may be used on the field of play and / or in the Technical Area.

"Technical Area" shall have the meaning given to it in the Laws of the Game.

[Note: In calculating the area of any Advertising referred to in these Regulations, the usual mathematical formula will be used, and any outlines or box surrounds of the relevant designation, message, name, logo, emblem or mark, and all included space, shall be considered as part of the area of Advertising. If any further guidance is needed please contact The Association – sanctioning@thefa.com]

A. GENERAL

1. Advertising on Clothing and Football Boots is only permitted during the period of a Match in accordance with these Regulations and the Laws of the Game. This applies to Players, including substitutes, any others in the Technical Area, including Club Officials and to Match Officials. The rules of an Affiliated Association or Competition may provide that for matches under their jurisdiction a Club is obliged to obtain permission for any of the Advertising listed in Section C below, subject always to these Regulations. Clubs must seek the permission of the Competition organiser in order to wear any items of Clothing during any pre-match warm-up, ceremony or player line up that bear any slogan or message not otherwise covered by these Regulations (for example but not limited to a message of support regarding an ill team-mate).

KIT AND ADVERTISING REGULATIONS

2. Where the rules of an Affiliated Association or Competition require a Club to obtain permission under A(1), a new application for permission must be made to the appropriate body each time it is proposed to amend the Advertising. Subject to the provisions of Section B2 and Section C(5) below, or any relevant provisions of the appropriate Competition, there is no restriction on the number of such applications that may be made during the course of each season.
3. Disciplinary action in accordance with the Rules may be taken against a Club, Player, Club Official or Match Official for any breach of these Regulations.
4. The appearance on, or incorporation in, any item of Clothing, Football Boots or Other Equipment of any distasteful, threatening, abusive, indecent, insulting, discriminatory or otherwise ethically or morally offensive message, or any political or religious message, is prohibited. The Advertising of tobacco products is prohibited.
5. A Club shall observe all recognised Advertising standards and in particular those of the Advertising Standards Authority.
6. Advertising entailing the use of numerals is permitted only if such numerals clearly form part of the Advertising and cannot in any way be confused with Players' shirt numbers.
7. No colour or design may be used in Advertising that might create problems of identification for Match Officials and/or opponents. The colour and design of the Clothing of opponents, goalkeepers and match officials must be taken into account.
8. Without limiting the effect of the above, in the case of a team comprising players all under the age of 18 years on 31 August in the current season, the appearance on or incorporation in any item of Clothing, Football Boots or Other Equipment of any reference whatsoever to a product, service or other activity which is considered by The Association as detrimental to the welfare, health or general interest of young persons, or is otherwise considered inappropriate, having regard to the age of the players, is prohibited.

It is the view of The Association that examples of such products, services or related activities would include, but are not limited to, age restricted products, services and related activities such as alcohol and gambling. Generally, reference to a public house or restaurant may be permissible, unless the establishment primarily or exclusively exists for the supply and consumption of alcohol (which is likely to be reflected in its alcohol licensing conditions). Alcoholic drinks, breweries and products, services or activities related to gambling are unlikely to be permissible under any circumstances.

Prior to entering into any contractual agreement with a product, activity or service that may be considered to be detrimental or inappropriate to young persons, clubs should contact The Association to seek approval.

9. Any issues arising in relation to the interpretation or effect of these Regulations shall be referred to The Association for its determination, which shall be final and binding (subject to provisions relating to Match Officials).
10. A Club shall supply on demand to The Association any item of Clothing for consideration as to whether it complies with these Regulations.

B. PERMITTED ADVERTISING (NOT RELATING TO SPONSORS)

The following Advertising is permitted:

1. Club emblem and name
 - (i) On Football Boots

The officially designated Club emblem (or part thereof), name, initials, nickname or a trademark registered by the Club, or a combination of such, may appear without restriction.
 - (ii) On all other Clothing

KIT AND ADVERTISING REGULATIONS

The officially designated Club emblem (or part thereof), name, initials, nickname, foundation year or a trademark by the Club, or a combination of such, may appear:

- (a) once only on the front of the shirt, providing it does not exceed an area of 100 square centimetres (see Fig 1); and
- (b) once only anywhere on the shorts providing it does not exceed an area of 50 square centimetres (see Fig 2); and
- (c) once only on each sock providing it does not exceed an area of 50 square centimetres (see Fig 3).

An additional officially designated Club emblem (or part thereof), name, initials, nickname or a trademark registered by the Club, or a combination of such, may appear on each sock providing it does not exceed an area of 50 square centimetres and, where it appears on a sock, is covered when a Football Boot is worn (see Fig 3).

- (d) once only on each sock tie-up providing it does not exceed an area of 100 square centimetres. The sock tie-up may show the Player's name, Player's squad number, Competition name, sponsor designation and date of match or any combination of the same. Clubs must receive the approval of the Competition for the use of sock tie-ups.
- (e) No more than two of the officially designated Club emblem (or part thereof), name, initials, nickname, foundation year, a trademark registered by the Club or web site address, may appear on the collar or collar zone of a shirt and/or tracksuit. Any single item may be used once only. Each item to have a surface area not exceeding 12 square centimetres, and any lettering in written / text identifications must not exceed 2 centimetres in height (see Fig 5). The collar zone is a 5 centimetre band starting at the base of a clearly defined collar.
- (f) The club may incorporate one of its types of club identification or parts thereof, in jacquard weave form, as tonal print or by embossing the shirt and/or shorts. There is no limitation as to the number, size and positioning of the type of club identification chosen.

The design of such jacquard weave may also be the names of individuals (eg club supporter) providing each is limited to 20 square centimetres, with unlimited repeats being acceptable. Clubs must receive the approval of the Competition to apply the names of individuals into a jacquard weave or similar technique.

The jacquard weave thread must be included in a thread that must be the same colour as the fabric into which it is woven. Tonal prints or embossing must be included in a tonal variation of the background colour(s) of the item of the shirt and/or shorts into which they are incorporated. The jacquard weave, embossing or tonal print must not dominate, contain a colour that contrasts with, or otherwise affect the distinctiveness of the shirt or shorts into which it is incorporated.

- (g) once only on the front of any walk on jackets and outer garments of Clothing including that worn by substitutes and Club Officials in the Technical Area at any time with size and positioning consistent with B1(ii)(a) and (b) above, except that there are no restrictions as to the position and size of the Club name. In addition once only on the back with no restriction as to the position or size.
- (h) Once only without restriction of location on:
 - (a) Goalkeeper's gloves and outfield player's gloves up to a maximum area of 20 square centimetres.
 - (b) sweatbands, headbands, goalkeeper's caps (see Fig 4) and hairbands up to a maximum area of 50 square centimetres.

KIT AND ADVERTISING REGULATIONS

2. Clothing Manufacturer

(i) On Football Boots

The established mark, logo, name or model/style of Football Boots or their manufacturer, or a combination of the same, may appear without restriction.

(ii) On all other Clothing

The established mark, logo or name of a Clothing manufacturer, or a combination of the same, may appear once only:

- (a) on the shirt and on the shorts provided it is an area no greater than 20 square centimetres (see Fig 7).
- (b) on each of a goalkeeper's gloves, on a goalkeeper's cap, sweatbands, headbands and hairbands provided such does not exceed an area of 20 square centimetres (see Fig 6).
- (c) on each of an outfield player's gloves provided such does not exceed an area of 20 square centimetres.
- (d) on the front and back of any t-shirt or any other item of Clothing worn under the shirt provided such does not exceed an area of 20 square centimetres and this is not visible outside the playing shirts during the period of the Match.
- (e) on undershorts worn under playing shorts provided such does not exceed an area of 20 square centimetres and this is not visible outside the playing shorts during the period of the Match.
- (f)
 - (i) The established mark, logo or name of a Clothing manufacturer, or a combination of the same, may also appear up to twice on each sock between the top edge and the ankle, provided that it is an area no greater than 20 square centimetres for such mark, logo or name (or combination thereof) where it appears once on each sock or 10 square centimetres where it appears twice on each sock. It may be incorporated into the design of the socks, but must be limited to 10 square centimetres repeats and must be restricted to any turn-over on the socks (see Fig 8).
 - (ii) An additional established mark, logo or name of a Clothing manufacturer, or a combination of the same, may appear once only on each sock providing it does not exceed an area of 50 square centimetres and it is not visible when wearing a Football Boot.
- (g)
 - (i) An additional established mark, logo or name of the Clothing manufacturer may be used once or repeatedly on either/or both sleeves as part of the design on the trim or taping of shirts, shorts and socks. Such trim or taping shall be limited to down the outer seam of the shirt (armhole to the bottom of the shirt), or the length of the sleeve (neck to cuff), or across the bottom of each sleeve (cuffs) and to the bottom edge of the shorts or down the outer seam of the shorts and across the top edge of the socks (see Fig 9).
 - (ii) The mark, logo or name of the Clothing manufacturer which appears once or repeatedly, as part of the design on the trim or taping of the shirts, shorts and socks shall be restricted to a maximum width of 10cm on the shirts and shorts and to a maximum width of 5cm on brand-new (unworn) socks (see Figs 8 and 9).
- (h) An established mark, logo or name or combination of the Clothing Manufacturer must appear on all Clothing of all Players and Club Officials wherever such Advertising appears consistent with the size and positioning set out at B.2(ii) above. Once submitted to and

KIT AND ADVERTISING REGULATIONS

approved by a Competition, the established mark, logo or name or combination on players' and Club Officials' Clothing may not be modified during the course of that season, without the approval of the Competition.

- (i) In addition to the club identification, the manufacturer may incorporate one of its types of identification in jacquard weave form or by embossing in the shirt and/or shorts. The type of manufacturer identification chosen must not exceed 20 square centimetres. There is no limitation as to the number and positioning of the type of manufacturer identification chosen.

The jacquard weave must be incorporated in the main colour and/ or one of the minor colours. It must neither dominate nor affect the distinctiveness of the kit.

3. Product marks and seals of quality

- (i) On Football Boots

The official licensing product mark or seal of quality is permitted on the outside of Football Boots without restriction.

- (ii) On all other Clothing

An official licensing product mark or seal of quality is permitted on the outside of the Clothing only if Competition rules so allow. When placed on a shirt, such mark or seal may not exceed 10 square centimetres in size and shall be placed on an area which is hidden when the shirt is tucked inside the shorts.

A second, smaller licensing mark or seal of quality is allowed on the shirt which must not exceed 5 square centimetres and must be placed along the torso outer seam. In addition to any licensing product mark(s) or seal(s) of quality which may appear on the shirt, such a mark or seal is permitted on the shorts. It may not exceed 5 square centimetres.

4. Numbers

- (i) On Football Boots

A Player's shirt number may appear on his boots without restriction.

- (ii) On all other Clothing

Where the Competition rules require a number on the back of the shirt, it should be clearly legible and positioned in the centre of the back of the shirt.

The number should be between 20 cm and 35 cm in height with provision for each competition to set specific criteria.

A number may also appear on the front of the shorts which must correspond with the number on the shirt.

The number should be between 10 cm and 15 cm in height with provision for each competition to set specific criteria.

Subject to any Competition rules that may apply, the officially designated logo or name of the Competition (or combination of the same) or the officially designated Club emblem may appear once only on each of the player's shirt numbers providing the logo, name or combination does not exceed an area of 20 square centimetres. The officially designated logo or name of the Competition's designated charity or combination of the same may also appear once only on each of the player's shirt numbers providing the logo, name or combination does not exceed an area of 20 square centimetres. No other Advertising or any other marking is allowed on players' shirt numbers.

KIT AND ADVERTISING REGULATIONS

5. Players Names and Personalisation

(i) On Football Boots

A Player's name, including any appropriate nickname or initials, may appear on that Player's boots without restriction. Other names, places, appropriate nicknames or numbers of personal significance to that Player (e.g. the name or birthday of a family member, or the number of playing appearances made) may also appear on that Player's boots without restriction.

(ii) On all other Clothing

The name of a player may appear on the back of shirts or tracksuits only if Competition rules so permit. The height of the lettering must not be greater than 7.5 centimetres.

6. Other Logos

(i) On Football Boots

Except as permitted by paragraphs 1 – 5 above, the appearance of any logo of any description on a Player's Football Boots is prohibited.

(ii) On goalkeeper gloves

A goalkeeper's name, including any appropriate nickname or initials, may appear on the goalkeeper's gloves providing such name etc does not exceed an area of 20 square centimetres.

(iii) On all other Clothing

(a) The officially designated logo or name of an Affiliated Association or Competition may appear as one single area on each sleeve of shirts, provided Affiliated Associations or Competition rules so permit. Such mark must appear between the shoulder seam and the elbow and must not exceed 100 square centimetres.

(b) The officially designated logo, name of any awards or titles won in previous seasons or commemorative occasions (which may include any match details e.g. date, venue, opponents) or a unique number for each Player that represents their place in the chronological list of Players that have played for that Club may appear as one single area on shirts, provided such does not exceed an area of 100 square centimetres and permission has been granted from the Competition in which the kit is to be worn.

(c) A single image of the national flag of the country to which the Club is affiliated may appear as one single area on each sleeve of the playing shirt provided that the rules of the Affiliated Associations and the Competition so permit and that it does not exceed an area of 25 square centimetres.

(d) The officially designated name, logo or emblem of a registered charity may appear as one single area on shirts, provided that such name, logo or emblem does not exceed an area of 100 square centimetres. Alternatively, such a charity name, logo or emblem may appear on shirts in the space reserved for the main club sponsor, either alone or in combination with a club sponsor logo, provided that a total area of 250 square centimetres is not exceeded.

Before any such charity name, logo or emblem is used on shirts, permission must be granted from the Competition in which the shirts are to be worn. Such permission may only be granted for a maximum of three charities for use by any one club in any one season. Competition requirements may also apply and are always subject to these Regulations.

KIT AND ADVERTISING REGULATIONS

- (e) A Competition may request permission from The Association for the inclusion of a designated name, logo or emblem of an initiative to appear as a single area on shirts, provided that such name, logo or emblem does not exceed an area of 100 square centimetres. Alternatively, such a name, logo or emblem may appear on shirts in the space reserved for the main club sponsor, either alone or in combination with a club sponsor logo, provided that a total area of 250 square centimetres is not exceeded. Permission will be at the sole discretion of The Association.
- (f) The captain of each team may wear an armband in accordance with Affiliated Association or Competition Rules. If worn the captain's armband must not include any form of Advertising or sponsorship. With the prior agreement of the Affiliated Association or Competition the captain's armband may include the official club emblem, the Affiliated Association or Competition logo, or any initiative or emblem that promotes the game of football.

CLUB EMBLEM

Regulation B.1

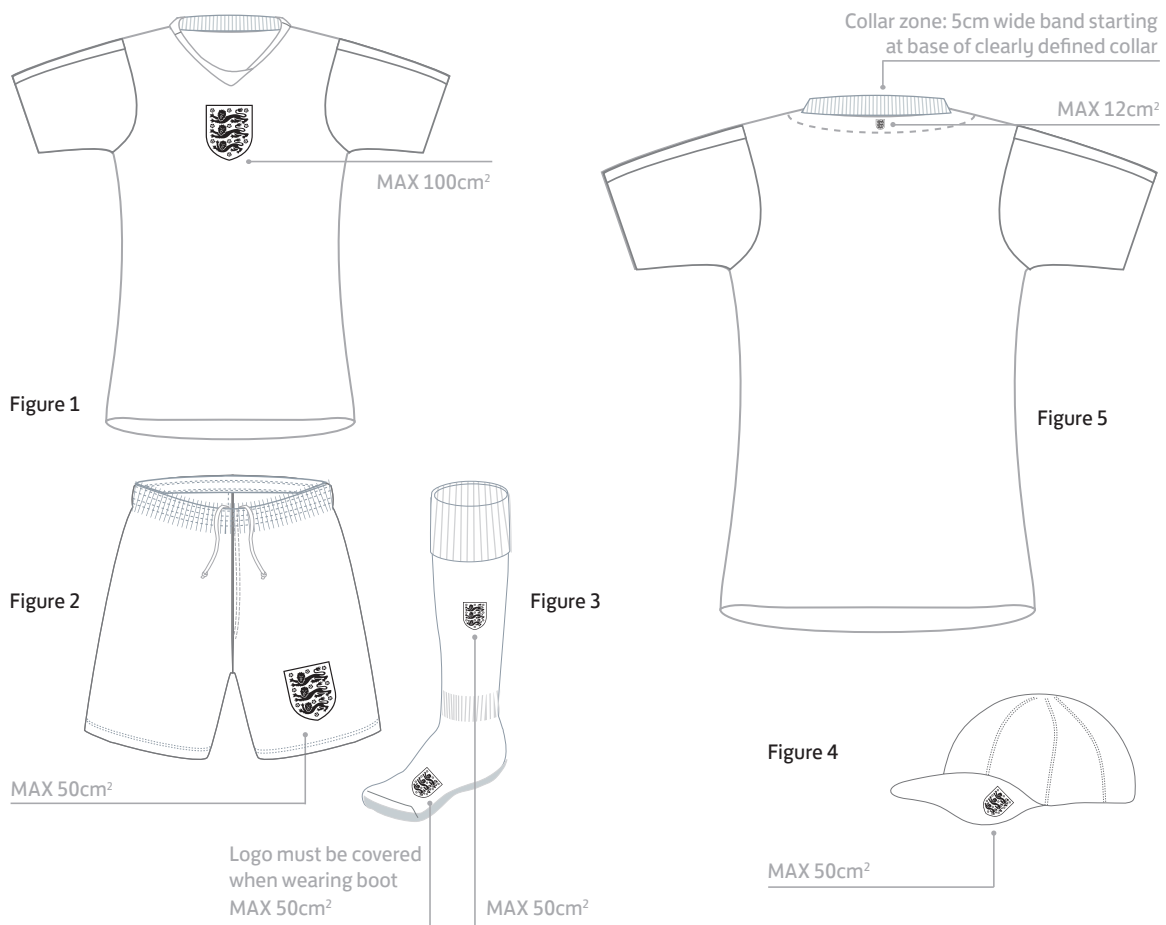

KIT AND ADVERTISING REGULATIONS

5. Players Names and Personalisation

(i) On Football Boots

A Player's name, including any appropriate nickname or initials, may appear on that Player's boots without restriction. Other names, places, appropriate nicknames or numbers of personal significance to that Player (e.g. the name or birthday of a family member, or the number of playing appearances made) may also appear on that Player's boots without restriction.

(ii) On all other Clothing

The name of a player may appear on the back of shirts or tracksuits only if Competition rules so permit. The height of the lettering must not be greater than 7.5 centimetres.

6. Other Logos

(i) On Football Boots

Except as permitted by paragraphs 1 – 5 above, the appearance of any logo of any description on a Player's Football Boots is prohibited.

(ii) On goalkeeper gloves

A goalkeeper's name, including any appropriate nickname or initials, may appear on the goalkeeper's gloves providing such name etc does not exceed an area of 20 square centimetres.

(iii) On all other Clothing

(a) The officially designated logo or name of an Affiliated Association or Competition may appear as one single area on each sleeve of shirts, provided Affiliated Associations or Competition rules so permit. Such mark must appear between the shoulder seam and the elbow and must not exceed 100 square centimetres.

(b) The officially designated logo, name of any awards or titles won in previous seasons or commemorative occasions (which may include any match details e.g. date, venue, opponents) or a unique number for each Player that represents their place in the chronological list of Players that have played for that Club may appear as one single area on shirts, provided such does not exceed an area of 100 square centimetres and permission has been granted from the Competition in which the kit is to be worn.

(c) A single image of the national flag of the country to which the Club is affiliated may appear as one single area on each sleeve of the playing shirt provided that the rules of the Affiliated Associations and the Competition so permit and that it does not exceed an area of 25 square centimetres.

(d) The officially designated name, logo or emblem of a registered charity may appear as one single area on shirts, provided that such name, logo or emblem does not exceed an area of 100 square centimetres. Alternatively, such a charity name, logo or emblem may appear on shirts in the space reserved for the main club sponsor, either alone or in combination with a club sponsor logo, provided that a total area of 250 square centimetres is not exceeded.

Before any such charity name, logo or emblem is used on shirts, permission must be granted from the Competition in which the shirts are to be worn. Such permission may only be granted for a maximum of three charities for use by any one club in any one season. Competition requirements may also apply and are always subject to these Regulations.

KIT AND ADVERTISING REGULATIONS

CLOTHING MANUFACTURER

Regulation B.2

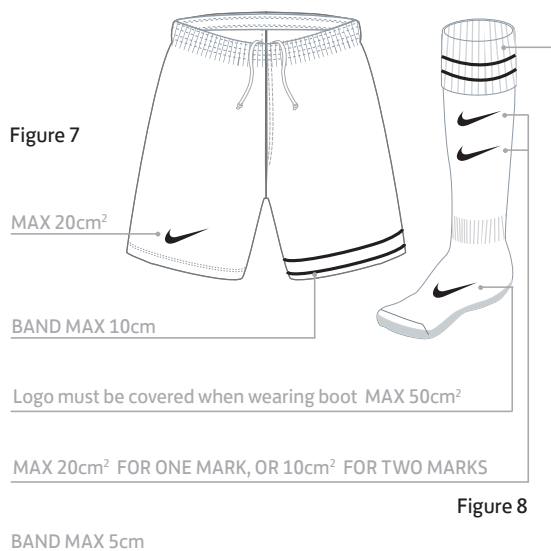

Figure 7

Figure 8

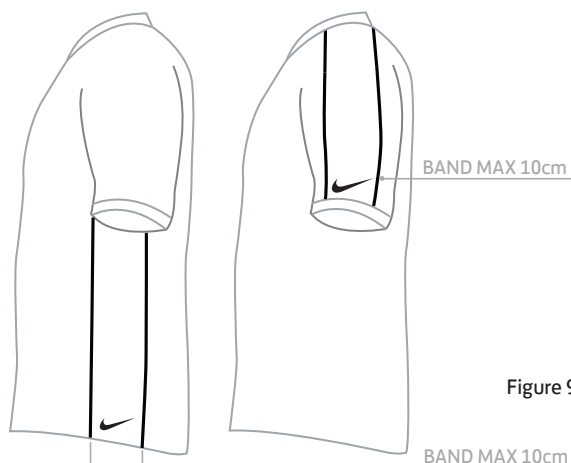

Figure 9

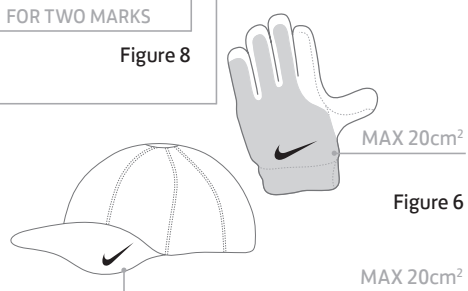

Figure 6

KIT AND ADVERTISING REGULATIONS

C. SPONSOR DESIGNATIONS

1. On Football Boots

Except as permitted by paragraphs B1 – 5 above, the appearance of any Advertising of any description, including sponsors' designations, on a Player's Football Boots is prohibited.

2. On all other Clothing

No sponsor Advertising is permitted anywhere on the Clothing of a Player on the field of play during a match except as provided for in this part C.

The following Advertising is permitted:

(i) Playing kit

(a) On the Clothing of a Player on the field of play, the following areas shall be permitted to be used for Advertising

- One single area not exceeding 250 square centimetres on the front of the shirt (see Fig 10);
- One single area not exceeding 100 square centimetres on the back of the shirt (see Fig 13);
- One single area not exceeding 100 square centimetres on each sleeve of the shirt, between the shoulder seam and the elbow (provided Affiliated Association or Competition Rules so permit) (see Fig 12);
- One single area not exceeding 100 square centimetres on the back of the shorts (see Fig 14); and
- Once only on each sock tie-up providing it does not exceed an area of 100 square centimetres (see Fig 11).

One or more company may be advertised and, in respect of any one company, one or more of its products. The same Advertising must appear in the same form on the Clothing of all Players and Club Officials, wherever such Advertising appears, throughout the entirety of the match.

(b) Any Advertising under C2(i) must be clearly separated from the items described in B above.

(ii) Walk on jackets and Tracksuits and other Clothing worn in the Technical Area

Advertising may appear on (a) walk on jackets; and (b) the tracksuits and other Clothing worn by Players and Club Officials in the Technical Area in accordance with the size and locations set out in C2(i) and can be either:

- the same sponsor(s) as worn on the playing kit (home or away strips)
- be additional to the sponsors as worn on the playing kit
- be different to the sponsors as worn on the playing kit
- a single sponsor that is an official partner of the relevant competition

3. Clubs may conclude sponsorship arrangements with different companies in respect of Advertising permitted under C2(i) above for both their 'home' and 'away' strips. Where Competition rules allow for a third strip to be worn, this may carry Advertising as worn on either the "home" or "away" shirt. The third strip may carry an alternative sponsor advertisement with the permission of the Competition. The Advertising must appear in the same form on the Clothing of all Players and Club Officials wherever such Advertising appears, throughout the entirety of the match.

KIT AND ADVERTISING REGULATIONS

4. Clubs with more than one team may conclude separate shirt Advertising agreements in respect of each of its teams.

5. Club playing name

No Club in Membership of the Premier League, EFL, a League at Steps 1 to 6 of the National League System, The FA Women's Super League, The FA Women's Championship or The FA Women's National League, may include the name of a sponsor in its Club playing name unless in the sole opinion of The Association the Club's playing name arises from a historical association with that Club such as a works sports and social club. Any other Club may include the name of a sponsor in its playing name with the prior written consent of its Affiliated Association and where such consent is given, Advertising on behalf of one company only shall be carried on the Club's match shirts irrespective of the provisions of B(4) and C2(i) above.

6. Competition Name

(i) Subject to paragraph 6(ii) below, a Competition may include the name of a sponsor in its title.

(ii) Where a Competition comprises teams of players all under the age of 18 years on 31 August in the current season, any reference whatsoever to a product, service or other activity which is considered by The Association as detrimental to the welfare, health or general interest of young persons, or is otherwise considered inappropriate, having regard to the age of the players, is prohibited.

Examples of such products, services or related activities shall include, but are not limited to, age restricted products, services and related activities such as alcohol and gambling. Reference to a public house or restaurant may be permissible, unless the establishment primarily or exclusively exists for the supply and consumption of alcohol (which may be reflected in its alcohol licensing conditions). Alcoholic drinks, breweries and products, services or activities related to gambling are unlikely to be permissible under any circumstances.

Prior to entering into any contractual agreement with a product, activity or service that may be considered to be detrimental or inappropriate to young persons, Competitions should seek approval from The Association or Affiliated Association from which it requests sanction.

KIT AND ADVERTISING REGULATIONS

SPONSOR DESIGNATIONS

Regulation C.2(i) front of the shirt and sock tie-up



Figure 10

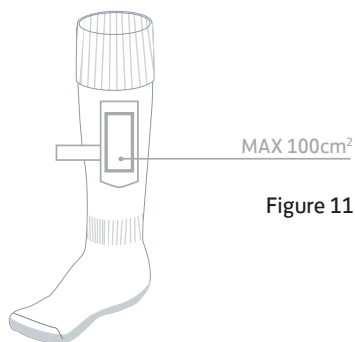

Figure 11

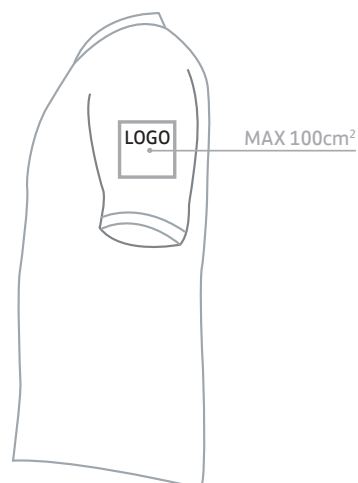
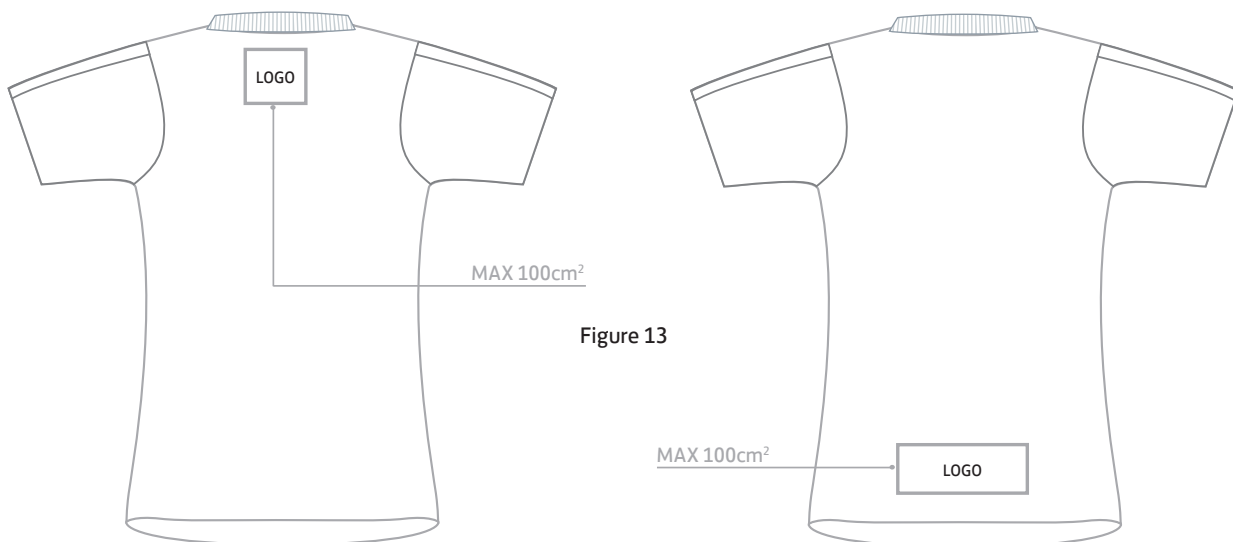

Figure 12

KIT AND ADVERTISING REGULATIONS

SPONSOR DESIGNATIONS

Regulation C.2(i) Back of the shirt and shorts



(Examples of where a single logo could be located)

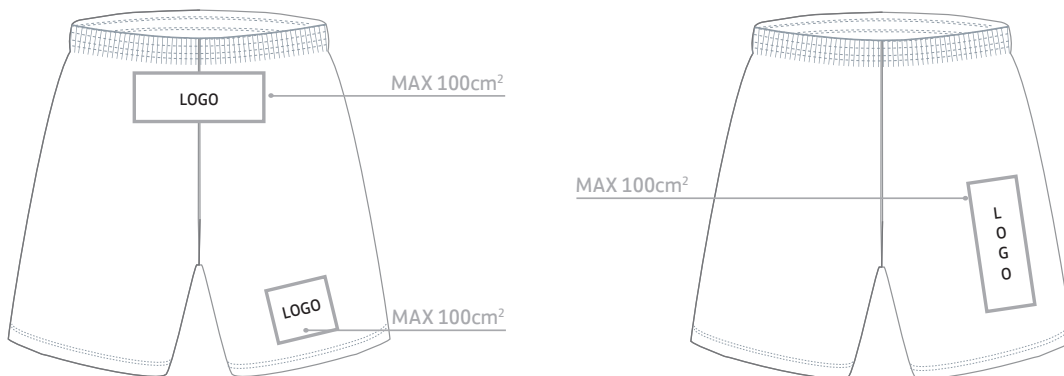

KIT AND ADVERTISING REGULATIONS

MEASUREMENT PROCEDURES

In order to help clubs maximise the space for their sponsors within the regulations, we have provided some practical examples of how The FA would measure sponsor advertising on football club shirts.

If you would like assistance or require clarification of measurement and sizing relevant to your club sponsor, please email sanctioning@TheFA.com



(A multiplied by B)

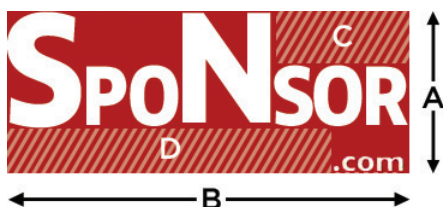

(A multiplied by B less C + D)

Items on kit will be measured according to their smallest geometric form (square, rectangle, triangle, circle etc), and the dimensions calculated using the usual mathematical formula.

To calculate the surface area, the widest part of the items will be measured from edge to edge. Exceptionally, items may be divided into several individual geometric forms for the purpose of calculating the surface area.

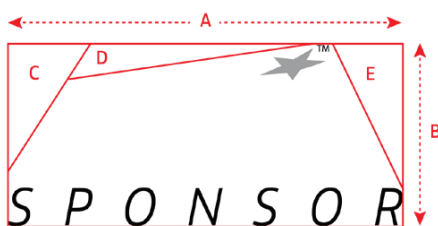

MAXIMUM 250cm²

(A multiplied by B less C + D + E)

KIT AND ADVERTISING REGULATIONS

MEASUREMENT PROCEDURES OF NEUTRAL COLOURED PATCHES/SHIRT COLOURS

- A. **Sponsor advertising on a neutral coloured patch** – i.e. white sponsor logo on a black patch on a predominantly white/green shirt.

In this scenario the area measured would be the total area covered by the black patch on which the logo sits.



- B. **Sponsor advertising on a patch which is based on one of the main colours of the shirt** – i.e. white sponsor logo on a red and white striped shirt.

In this scenario the area measured would only be that around the sponsor's logo even if this logo may stand out more prominently because of the white stripes in the shirt.



- C. **Measuring of a 'chest ring'** – e.g. the white band around a club's shirt

If a club's traditional shirt contains a chest ring and that is one of the official colours of the playing kit, the area that is measured will only be around the sponsor's logo and not the whole of the chest ring.



KIT AND ADVERTISING REGULATIONS

D. MATCH OFFICIALS

No Advertising of any nature, save as set out below, is permitted on Match Officials' Clothing or Football Boots without the consent of The Association.

The following Advertising is permitted:

1. The mark, logo or name of a Clothing manufacturer or a combination of the same, may appear:
 - (a) once only on the shirt provided it is an area no greater than 20 square centimetres.
 - (b) once only on the shorts provided it is an area no greater than 12 square centimetres.
 - (c) incorporated into the design of the socks, but must be limited to an area no greater than 12 square centimetres.
2. Jacquard Weave

A jacquard weave or similar technique such as embossing shall be allowed providing each is limited to 20 square centimetres, with unlimited repeats being acceptable. The design of such jacquard weave may be the manufacturer's mark, logo or name. The jacquard weave shading shall be restricted to two shades differing from the base colour, using a standard Pantone reference manual.
3. Sponsor Advertising

Sponsor Advertising is permitted only on shirt sleeves and the total surface area of the Advertising shall not exceed 200 square centimetres. Any sponsorship contract must be made between the sponsor and The Association or Professional Game Match Officials Limited. Individual Affiliated Associations or Leagues are not permitted to enter into sponsorship contracts.
4. Badges

Match kit shirts may carry the recognised badge of the appropriate Competition once only, which must be on either site of the breast pocket. This badge must not exceed an area of 20 square centimetres and, where it contains the established trademark, trade name or logo of a sponsor of the Competition, must be approved by The Association in advance.

In addition to the recognised competition badge the match kit shirt may carry once only on either site of the breast pocket an officially designated badge of FIFA, The Association, the relevant Affiliated Association or the Referees' Association (where relevant).
5. Sock Tie-Up

Each sock tie-up may show the name and/or badge of appropriate Affiliated Association or the Referees' Association providing it does not exceed an area of 100 square centimetres.

No Advertising is allowed.

A GUIDE TO THE FA KIT AND ADVERTISING REGULATIONS

Season 2020-21



The Football Association
Wembley Stadium
PO Box 1966
London
SW1P 9EQ

T +00 (0)800 169 1863
F +00 (0)208 782 6740
E info@TheFA.com

www.TheFA.com

TheFA.com